

Reliable performance
Economical precision weighing
Durable construction

NEW!

- BENCH SCALE SERIES FROM TRINER SCALE
- AVAILABLE IN THREE SIZES & TWO CAPACITIES
- DATALOG PC COMPATIBLE

Model TBS-2424

- 1,000 lb x 0.2 lb
- 24" x 24"

Model TBS-1616

- 250 lb x .05 lb
- 16" x 16"



NTEP Approved
 Legal for Trade

Model TBS-1212

- 250 lb x .05 lb
- 12" x 12"

TBS Series Bench Scales by **Triner Scale**

- TUBULAR STEEL FRAME**
- CHECKWEIGHING FUNCTION**
- MAXIMUM WEIGHT HOLD**
- FOUR OVERLOAD STOPS**
- SUPER-BRIGHT LED READOUT**
- STAINLESS STEEL PLATFORM**

NEW!

TBS Series

Bench Scales from Triner Scale



NTEP Approved
Legal for Trade

TRINER SCALE

"Scales for Business and Industry Since 1897"

SPECIFICATIONS

General

- NTEP approved, Legal For Trade
- Stainless steel platform
- All steel tubular frame
- Adjustable, lockable leveling feet
- Leveling bubble
- Checkweighing function with Over, Under, and OK icons
- Hold options:
 - Manual hold
 - Auto hold
 - Peak Hold
- Selectable kg/lb
- Super-bright LED display
- RS-232 interface for connecting to printer, remote display or PC

Technical

- Keys
 - On/Off
 - Hold
 - Total
 - kg/lb
 - Gross
 - Tare
 - Zero
 - Print (sends data to printer or PC)
- Status displayed for:
 - Center of Zero
 - Stable
 - Gross
 - Net
 - Tare
 - Total
 - Hold
 - lb
 - kg
 - Hi/Ok/Lo (checkweigh)
- Operating Parameters
 - AC Power: 100 - 250V
 - Operating Temperature:
 - 10° C - +40° C
- Includes 110 VAC adapter
- Shipping Weight:
 - TBS-1212 = 24 lbs
 - TBS-1616 = 33 lbs
 - TBS-2424 = 81 lbs

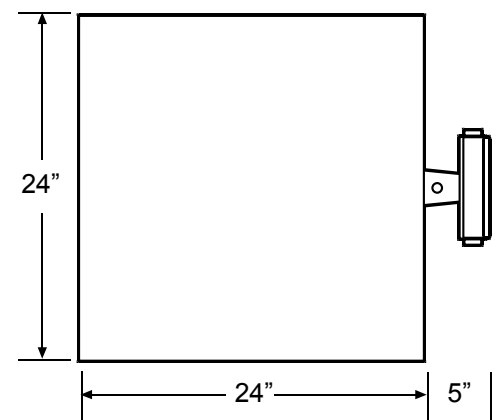
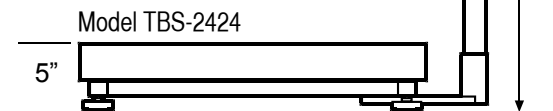
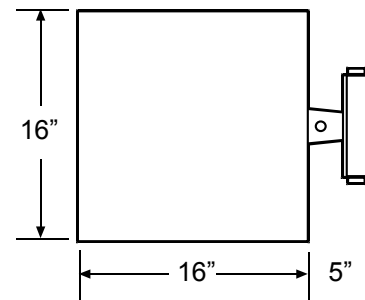
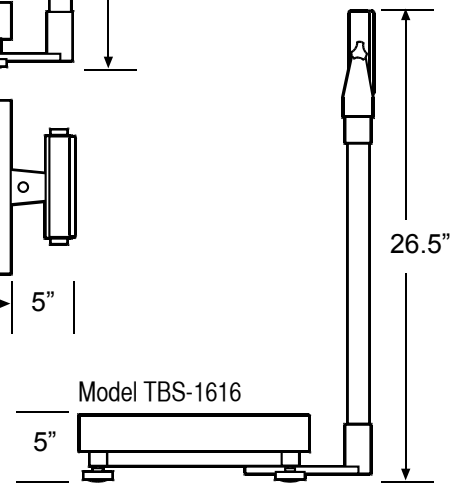
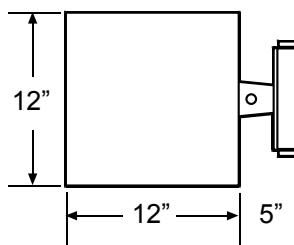
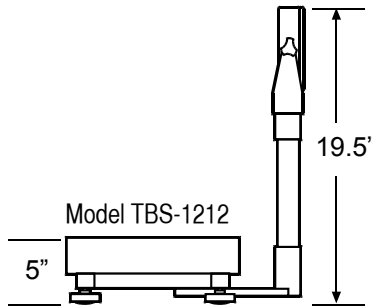

RS-232 Output Options

- Ticket Printer
- Remote Display
- Record weigh data to PC (Triner DataLog PC software compatible)

Triner Scale and Manufacturing Company, Inc.
Toll Free: (800) 238-0152
Tel: (662) 890-2385 Fax: (662) 890-2386
www.trinerscale.com